

SPECIFICATIONS	
CONTACT CARRIER MATERIAL	TPU
CONTACT MATERIAL/PLATING	BRASS/GOLD
HOUSING MATERIAL/PLATING	BRASS/NICKEL
GASKET MATERIAL	NITRILE
RATED CURRENT [A]	9.0 A
RATED VOLTAGE [V]	600 V
CONDUCTOR INSULATION MATERIAL	PVC
NUMBER OF CONDUCTORS [AWG]	4x18 AWG
TEMPERATURE RATING	-40°C to +105°C (-40°F to +176°F)
PROTECTION CLASS	NEMA 1,3,4,6P,12 & IECIP67, IP68,IP69,IP69K
ACCOMODATE WALL THICKNESS	1.3 [.050] to 6.4 [.250]

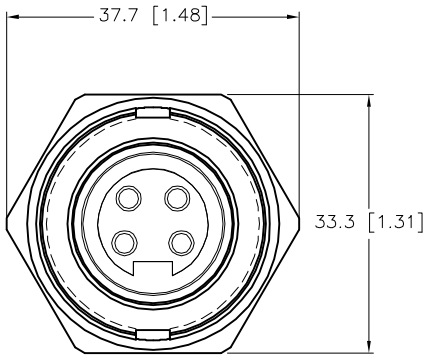

END VIEW
LOCKNUT NOT SHOWN

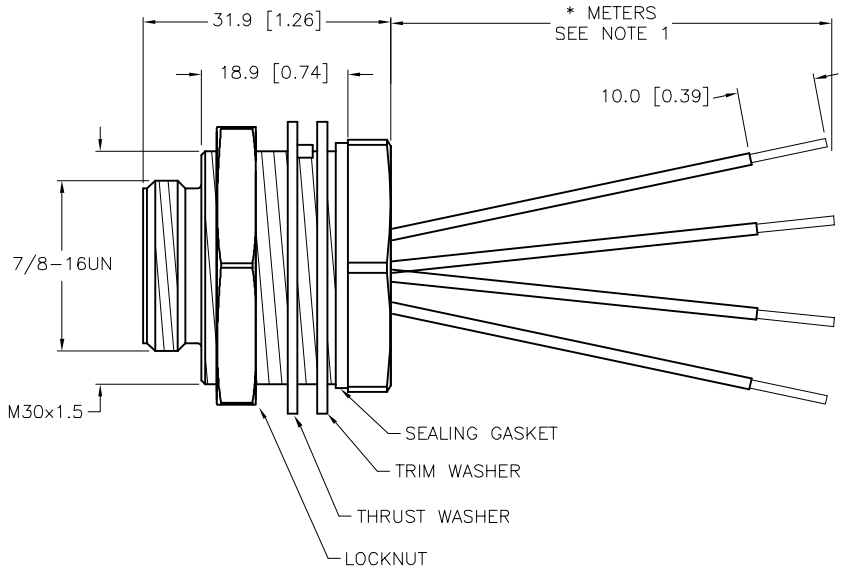

CABLE LENGTH	TOLERANCE*
ALL LENGTHS	+ 4% (OR 50mm) OF LENGTH - 0% (OR 0mm) OF LENGTH WHICHEVER IS GREATER
STRIP LENGTH	TOLERANCE*
0-7mm	±0.5mm
8-29mm	±1.0mm
30-49mm	±2.0mm
50-69mm	±3.0mm
70-100mm	±4.0mm
OVER 100mm	±5.0mm

* UNLESS OTHERWISE SPECIFIED

NOTE:
1. "*" INDICATES LEAD LENGTH IN METERS. CONTACT TURCK TO ORDER SPECIFIC LENGTHS.

SOURCE DRAWING - FOR REFERENCE ONLY

RELATED DOCUMENTS 1. 2. 3. 4.	3RD ANGLE PROJECTION 	THIS DRAWING IS CONFIDENTIAL AND THE PROPERTY OF TURCK INC. USE OF THIS DOCUMENT WITHOUT WRITTEN PERMISSION IS PROHIBITED.		 3000 CAMPUS DRIVE MINNEAPOLIS, MN 55441 1-800-544-7769 (763) 553-7300 (763) 553-0708 fax www.turck.us
		DRFT	RDS	
MATERIAL SEE SPECIFICATIONS	ALL DIMENSIONS DISPLAYED ON THIS DRAWING ARE FOR REFERENCE ONLY	APVD	SCALE 1=1.0	DESCRIPTION RSFP 40-*M
FINISH SEE SPECIFICATIONS		UNIT OF MEASUREMENT MILLIMETER [INCH]		IDENTIFICATION NO.
DO NOT SCALE THIS DRAWING		FILE: 777001846		REV D
D	UPDATE PROTECTION CLASS	CBM	04/13/21	76628
REV	DESCRIPTION	BY	DATE	ECO NO.